

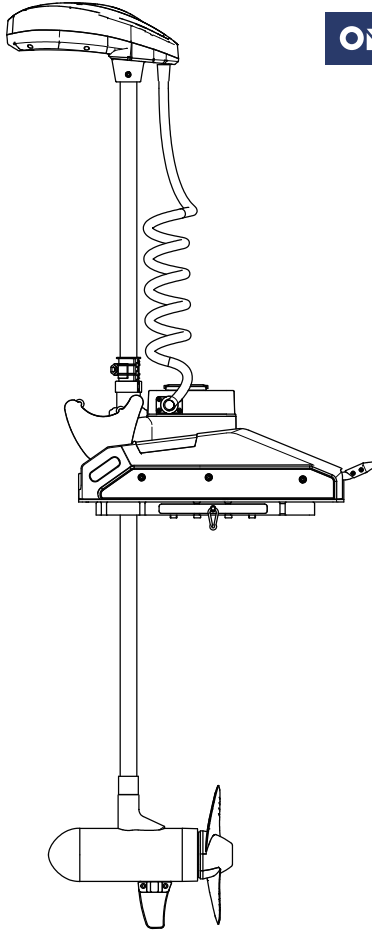

MAKOSHARK

OMAS SERIES



OMAS
SERIES
Owner's Manual

Model:
OMS150
OMS250
OMS255

TABLE OF CONTENTS

SAFETY CONSIDERATIONS	3
WARRANTY	4
FEATURES	5
INSTALLATION	6
Installing the OMAIS	6
COPILOT	7
Controlling the motor with copilot	7
BATTERY & WIRING INSTALLATION	13
Boat Rigging & Product Installation	13
Conductor Gauge and Circuit Breaker Sizing Table	13
Selecting the Correct Batteries	14
Additional Considerations	14
Connecting the Batteries	15
PARTS DIAGRAM & PARTS LIST	16
PARTS DIAGRAM & PARTS LIST 1	17
PARTS DIAGRAM & PARTS LIST 2	18

SAFETY CONSIDERATIONS

Please thoroughly read the user manual. Follow all instructions and heed all safety and cautionary notices. Use of this motor is only permitted for persons that have read and understood these user instructions. Minors may use this motor only under adult supervision.

WARNING

You are responsible for the safe and prudent operation of your vessel. We have designed your MAKOSHARK product to be an accurate and reliable tool that will enhance boat operation and improve your ability to catch fish. This product does not relieve you from the responsibility for safe operation of your boat. You must avoid hazards to navigation and always maintain a permanent watch so you can respond to situations as they develop. You must always be prepared to regain manual control of your boat. Learn to operate your MAKOSHARK product in an area free from hazards and obstacles.

WARNING

Never run the motor out of the water, as this may result in injuries from the rotating propeller. The motor should be disconnected from the power source when it is not in use or is off the water. When connecting the power-supply cables of the motor to the battery, ensure that they are not kinked or subject to chafe and route them in such a way that persons cannot trip over them. Before using the motor make sure that the insulation of the power cables is not damaged. Disregarding these safety precautions may result in electric shorts of battery(s) and/or motor. Always disconnect motor from battery(s) before cleaning or checking the propeller. Avoid submerging the complete motor as water may enter the lower unit through control head and shaft. If the motor is used while water is present in the lower unit considerable damage to the motor can occur. This damage will not be covered by warranty.

WARNING

Take care that neither you nor other persons approach the turning propeller too closely, neither with body parts nor with objects. The motor is powerful and may endanger or injure you or others. While the motor is running watch out for persons swimming and for floating objects. Persons who lack the ability to run the motor or whose reactions are impaired by alcohol, drugs, medication, or other substances are not permitted to use this motor. This motor is not suitable for use in strong currents. The constant noise pressure level of the motor during use is less than 70dB(A) . The overall vibration level does not exceed 2,5 m/sec².

WARNING

When stowing or deploying the motor, keep fingers clear of all hinge and pivot points and all moving parts. In the event of unexpected operation, remove power leads from the battery.

WARNING

It is recommended to only use MAKOSHARK approved accessories with your MAKOSHARK motor. Using non-approved accessories including to mount or control your motor may cause damage, unexpected motor operation and injury. Be sure to use the product and approved accessories, including remotes, safely and in the manner directed to avoid accidental or unexpected motor operation. Keep all factory installed parts in place including motor and accessory covers, enclosures and guards.

WARRANTY

Makoshark extends the following limited warranty to the original retail purchaser only. Warranty coverage is not transferable.

MAKOSHARK Limited Two-Year Warranty on the Entire Product

Makoshark warrants to the original retail purchaser only that the purchaser's new MAKOSHARK saltwater trolling motor will be materially free from defects in materials and workmanship appearing within Two(2)years after the date of purchase. Makoshark will(at its option)either repair or replace, free of charge, motor and controller by Makoshark to be defective during the term of this warranty. Such repair, or replacement shall be the sole and exclusive liability of Makoshark and the sole and exclusive remedy of the purchaser for breach of this warranty.

MAKOSHARK Limited Lifetime Warranty on Composite Shaft

Makoshark warrants to the original retail purchaser only that the composite shaft of the purchaser's MAKOSHARK trolling motor will be materially free from defects in materials and workmanship appearing within the original purchaser's lifetime. Makoshark will provide a new composite shaft, free of charge, to replace any composite shaft found by Makoshark to be defective during the term of this warranty. Providing a new composite shaft shall be the sole and exclusive liability of Makoshark and the sole and exclusive remedy of the purchaser for breach of this warranty; and purchaser shall be responsible for installing, or for the cost of labor to install, any new composite shaft provided by Makoshark.

Exclusions & Limitations

This limited warranty does not apply to easily worn machine parts (including carbon brush) does not apply to products that have been used commercially or for rental purposes. This limited warranty does not cover normal wear and tear, blemishes that do not affect the operation of the product, or damage caused by accidents, abuse, alteration, modification, shipping damages, negligence of the user or misuse, improper or insufficient care or maintenance. **DAMAGE CAUSED BY THE USE OF OTHER REPLACEMENT PARTS NOT MEETING THE DESIGN SPECIFICATIONS OF THE ORIGINAL PARTS WILL NOT BE COVERED BY THIS LIMITED WARRANTY.** The cost of normal maintenance or replacement parts which are not in breach of the limited warranty are the responsibility of the purchaser. Prior to using products, the purchaser shall determine the suitability of the products for the intended use and assumes all related risk and liability. Any assistance Makoshark provides to or procures for the purchaser outside the terms, limitations or exclusions of this limited warranty will not constitute a waiver of the terms, limitations or exclusions, nor will such assistance extend or revive the warranty. Makoshark will not reimburse the purchaser for any expenses incurred by the purchaser in repairing, correcting or replacing any defective products or parts, except those incurred with Makoshark's prior written permission.

Makoshark's AGGREGATE LIABILITY WITH RESPECT TO COVERED PRODUCTS IS LIMITED TO AN AMOUNT EQUAL TO THE PURCHASER'S ORIGINAL PURCHASE PRICE PAID FOR SUCH PRODUCT.

MAKOSHARK Service Information

To obtain warranty service, the product believed to be defective, and proof of original purchase (including the date of purchase), must be presented to a MAKOSHARK. Any charges incurred for service calls, transportation or shipping/freight to/from the MAKOSHARK Authorized Service Center or factory, labor to haul out, remove, re-install or re-rig products removed for warranty service, or any other similar items are the sole and exclusive responsibility of the purchaser. Products purchased outside of China, must be returned prepaid with proof of purchase (including the date of purchase and serial number) to any Authorized MAKOSHARK Service Center in the country of purchase. Warranty service can be arranged by contacting a MAKOSHARK Authorized Service Center. **Products repaired or replaced will be warranted for the remainder of the original warranty period (or for 90 days from the date of repair or replacement, whichever is longer).** For any product that is returned for warranty service that Makoshark finds to be not covered by or not in breach of this limited warranty, there will be a billing for services rendered at the prevailing posted labor rate and for a minimum of at least one hour.

NOTICE: Do not return your MAKOSHARK product to your retailer. Your retailer is not authorized to repair or replace

NOTICE: THERE ARE NO EXPRESS WARRANTIES OTHER THAN THESE LIMITED WARRANTIES. IN NO EVENT SHALL ANY IMPLIED WARRANTIES INCLUDING ANY IMPLIED WARRANTIES OF MERCHANTABILITY OR FITNESS FOR PARTICULAR PURPOSE, EXTEND BEYOND THE DURATION OF THE RELEVANT EXPRESS LIMITED WARRANTY. IN NO EVENT SHALL Makoshark BE LIABLE FOR PUNITIVE, INDIRECT, INCIDENTAL, CONSEQUENTIAL OR SPECIAL DAMAGES. Without limiting the foregoing, Makoshark assumes no responsibility for loss of use of product, loss of time, inconvenience or other damage.

Some states do not allow limitations on how long an implied warranty lasts or the exclusion or limitation of incidental or consequential damages, so the above limitations and/or exclusions may not apply to you. This warranty gives you specific legal rights and you may also have other legal rights which vary from state to state.

FEATURES

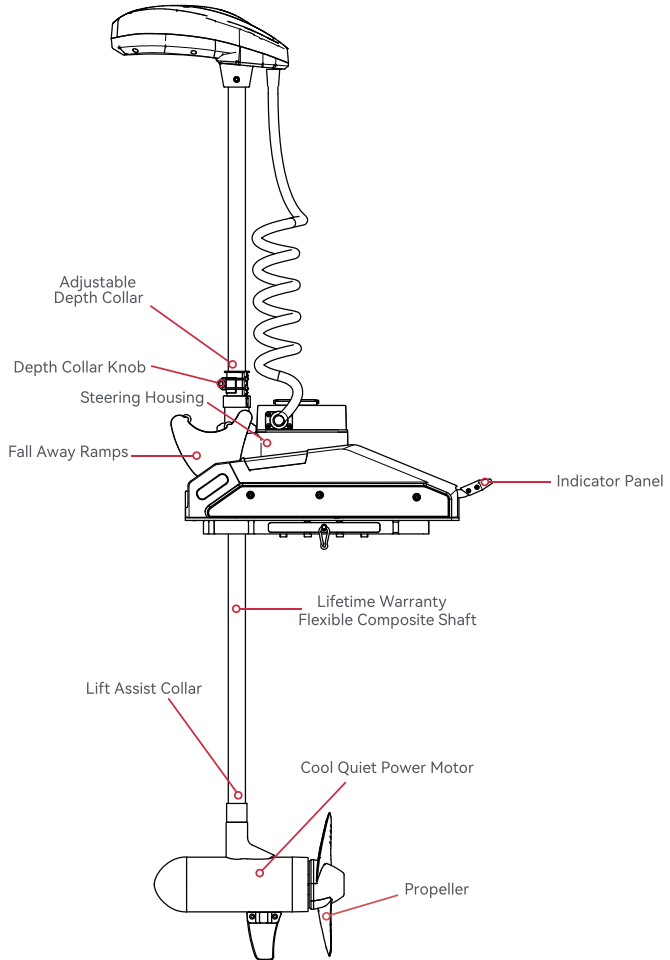

NOTICE: Specifications subject to change without notice. This diagram is for reference only and may differ from your actual motor.

INSTALLATION

INSTALLING THE OMAIS

Your new comes with everything you'll need to directly install it to the boat. This motor can be directly mounted to the boat or coupled with a quick release bracket for ease of mounting and removal. For installation with a quick release bracket, refer to the installation instructions provided with the bracket. For compatible quick release mounting brackets and to locate your nearest dealer, visit www.makoshark.cn. To install the motor directly to the boat, please follow the instructions provided in this manual. Please review the parts list, mounting considerations and tools needed for installation prior to getting started. For additional product support, please visit www.makoshark.cn.

INSTALLATION PARTS LIST >

Item / Assembly	Description	Qty.
1	Remote Control	1
2	External Sensor (Optional)	1
3	Propellor	1
4	M10 nut	1
5	M15 hexagonal spanner	1
6	Fins	1
7	M5*16 hexagon socket screws	2
8	M5 nut	2
9	M6*16 hexagon socket screws	4
10	gaskets	1
11	M6*25 hexagon socket screw	12
12	M6 nut	4
13	Plastic quick release Bracket	1

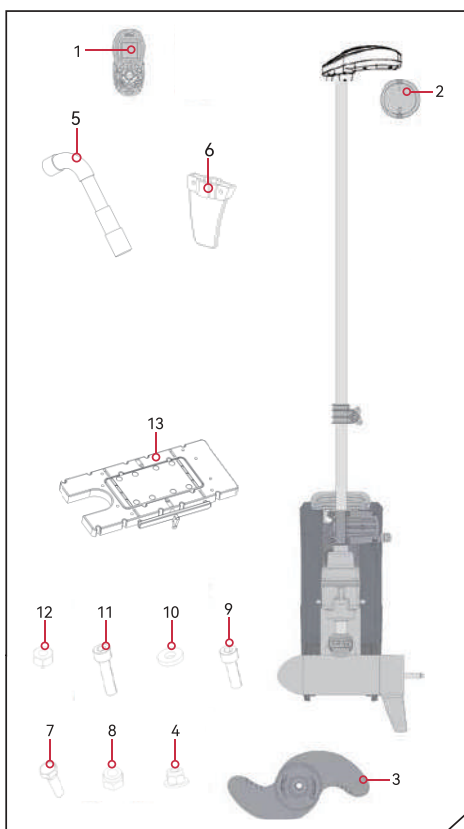

COPILOT

CONTROLLING THE MOTOR WITH COPILOT

Review the complete CoPilot section of this manual to become familiar with this feature. For more information on CoPilot or for additional product support, please visit www.makoshark.cn.

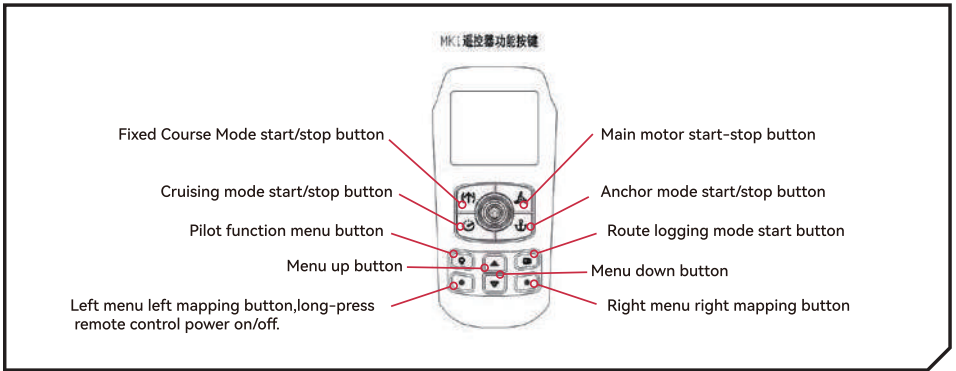

› Prop ON/OFF

This button is located in the middle of the remote. It turns the propeller on or off. Press the button once to turn the propeller ON; press button a second time to turn it OFF. The button does not need to be held down.

› Steer Left & Steer Right

These buttons are located to the right and left of the Prop ON/OFF button and have an arrow symbol. They cause the motor to turn in the desired direction as long as the button is held down. If the Steer Right or Steer Left button is held for more than seven seconds, the steering will automatically stop until the button is pressed again.

› Increase Speed & Decrease Speed

The Increase Speed and Decrease Speed buttons are located above the Prop ON/OFF button and are identified with a positive and negative symbol. Pressing and releasing these buttons causes the speed to increase or decrease by increments of 1. The speed is adjustable from level 0-10. At level 0, the prop will not turn.

In audio mode 2, an audible beep is heard for each increment when changing speed. Attempting to go higher than speed 10 or lower than speed 0 will result in the speed not changing and no beep will be heard. See the Audio Mode section for more information.

If the receiver senses no foot pedal or remote operation for 1 hour, the remote speed setting is automatically set to zero. This helps prevent unintentional activation of the propeller if the prop on/off remote button is inadvertently pressed.

INSTALLING THE OMAIS

MOUNTING CONSIDERATIONS

It is recommended that the motor be mounted as close to the centerline of the boat as possible. Make sure the area under the mounting location is clear to drill holes and install nuts and washers. Make sure the motor rest is positioned far enough beyond the edge of the boat. The motor must not encounter any obstructions as it is lowered into the water or raised into the boat when stowed and deployed. Consider a quick release or adapter bracket with the installation of your motor.

TOOLS AND RESOURCES REQUIRED

- Phillips Screw Driver
- Drill
- Drill Bit
- Box End Wrench
- A second person to help with the installation

INSTALLATION

INSTALLING THE OMAIS

1. a. Place the mount on an elevated, level surface such as a workbench or the tailgate of a pickup. The motor, as removed from the box, should be in the stowed position.
b. Remove the four sideplate screws using a Phillips screwdriver. Two of these screws will be located on each side of the mount.

NOTICE: This motor weighs approximately 65lbs. MAKO SHARK recommends having a second person help with the installation.

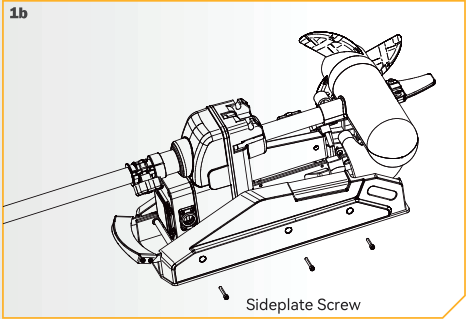

INSTALLING THE OMAIS

- 2**
- c. Remove the Right Sideplate.
 - d. Swing the Left Sideplate out and away from the Base Extrusion.

2c

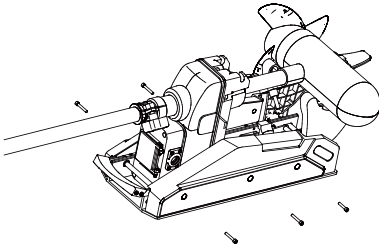

2d

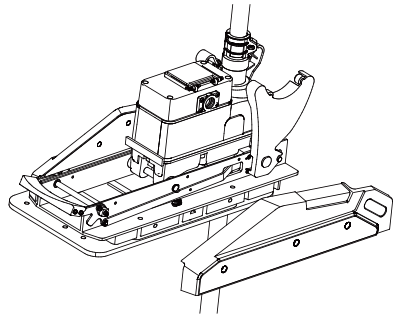

- 3**
- e. Make sure that the Power Cables from the battery are disconnected, or that the breaker, if equipped, is "off."



WARNING

Make sure the motor is mounted on a level surface and is not connected to a power source.

Power Cables

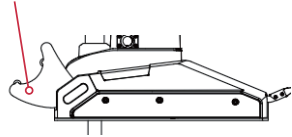

- 4**
- f. Place the mount as close to the centerline or keel of the boat as possible. The motor can be installed on either the Port or Starboard side of the boat based on personal preference. Check placement with the motor in the stowed and deployed positions. Review the mounting considerations at the beginning of the installation.

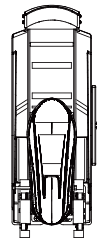

INSTALLING THE OMAIS

5

- i. It is recommended to mark 4 of the 4 holes in the Base Extrusion .
- j. Drill through the deck of the boat using a Drill Bit on the marked locations.

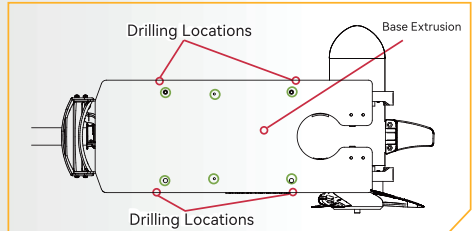

INSTALLING THE OMAIS

6

- k. Put a screw in each of the drilled locations. The screw should pass through the Base Extrusion and the boat deck. If the rubber washers are used, they should sit between the Base Extrusion and boat deck. Make sure to secure the motor with screws on each side of the Base Extrusion.
- l. Place a Flat Washer and then a Nylock Nut at the end of each screw as shown and secure. Make sure all hardware is secure.

NOTICE: To prevent seizing of the stainless steel hardware, do not use high speed installation tools. Wetting the screws or applying an anti-seize may help prevent seizing.

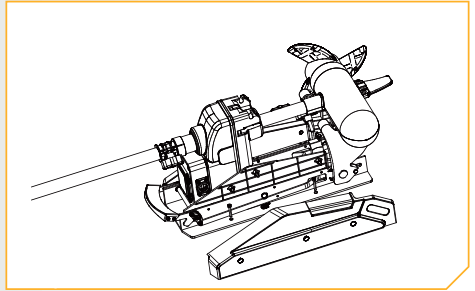

7

- m. Replace the Right Sideplate.
- n. Swing the Left Sideplate back into its correct position on the Base Extrusion.

7m

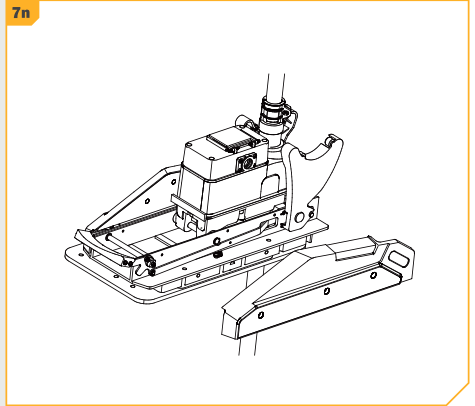
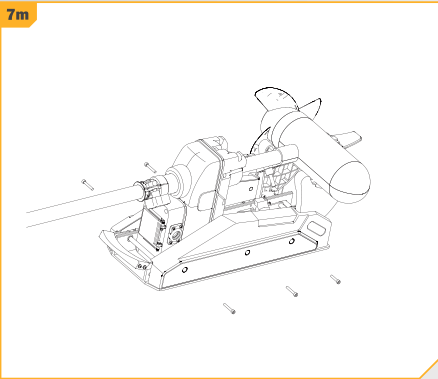

ROUTING THE LINK CABLE

8

- o. Replace the four sideplate screws using a Phillips screwdriver. Two of these screws will be located on each side of the mount.

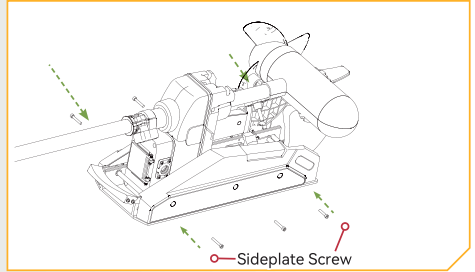

ROUTING THE LINK CABLE

Your trolling motor may be pre-installed with either Link. To learn more about the GPS capabilities available with your Link navigation system, please refer to the corresponding Owner's Manual by visiting www.makoshark.cn.

The Link features require a cable to be connected to an output device. This connection is present on the trolling motor below the Control Head, if installed. The system does not need an external wired connection. If only one connection is present, your motor is equipped with Link system. If no connections are present, your motor may or may not be installed with it. Please follow the MAKOSHARK recommendations on routing the cables to optimize mobility and maximize functionality. The routing will be the same regardless of the number of cables present. Use the following instructions to properly route cables.

Cables are shielded to minimize interference. To protect this shielding the cables should not be pulled tight against sharp angles or hard objects. If using cable ties, do not over-tighten. Any excess cable should be bundled in a loose loop of no less than 1 inch in diameter.

To minimize trolling motor interference, ensure that the fish finder and trolling motor are powered by separate batteries. Please refer to the Battery & Wiring Installation and Motor Wiring Diagram sections of this manual for correct rigging instructions.

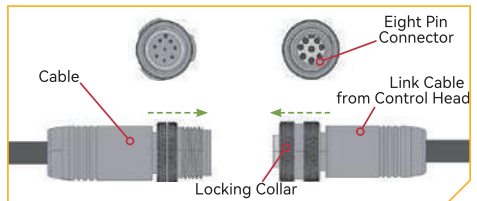

BATTERY & WIRING INSTALLATION

BOAT RIGGING & PRODUCT INSTALLATION

For safety and compliance reasons, we recommend that you follow American Boat and Yacht Council (ABYC) standards when rigging your boat. Altering boat wiring should be completed by a qualified marine technician. The following specifications are for general guidelines only:

CAUTION

These guidelines apply to general rigging to support your MAKOSHARK motor. Powering multiple motors or additional electrical devices from the same power circuit may impact the recommended conductor gauge and circuit breaker size. If you are using wire longer than that provided with your unit, follow the conductor gauge and circuit breaker sizing table below. If your wire extension length is more than 25 feet, we recommend that you contact a qualified marine technician.

CAUTION

An over-current protection device (circuit breaker or fuse) must be used. Coast Guard requirements dictate that each ungrounded current-carrying conductor must be protected by a manually reset, trip-free circuit breaker or fuse. The type (voltage and current rating) of the fuse or circuit breaker must be sized accordingly to the trolling motor used. The table below gives recommended guidelines for circuit breaker sizing.

CONDUCTOR GAUGE AND CIRCUIT BREAKER SIZING TABLE

This conductor and circuit breaker sizing table is only valid for the following assumptions:

1. No more than 2 conductors are bundled together inside of a sheath or conduit outside of engine spaces.
2. Each conductor has 105° C temp rated insulation.
3. No more than 5% voltage drop allowed at full motor power based on published product power requirements.

Motor Thrust / Model	Max Amp Draw	Circuit Breaker	Wire Extension Length				
			5 feet	10 feet	15 feet	20 feet	25 feet
30 lb.	30	50 Amp @ 12 VDC	10 AWG	10 AWG	8 AWG	6 AWG	4 AWG
40 lb., 45 lb.	42		10 AWG	8 AWG	6 AWG	4 AWG	4 AWG
50 lb., 55 lb.	50	60 Amp @ 12 VDC	8 AWG	6 AWG	4 AWG	4 AWG	2 AWG
70 lb.	42	50 Amp @ 24 VDC	10 AWG	10 AWG	8 AWG	8 AWG	6 AWG
80 lb.	56	60 Amp @ 24 VDC	8 AWG	8 AWG	8 AWG	6 AWG	6 AWG
101 lb.	46	50 Amp @ 36 VDC	8 AWG	8 AWG	8 AWG	8 AWG	8 AWG
Engine Mount 101	50	60 Amp @ 36 VDC	8 AWG	8 AWG	8 AWG	8 AWG	8 AWG
112 lb.	52	60 Amp @ 36 VDC	8 AWG	8 AWG	8 AWG	8 AWG	8 AWG
Engine Mount 160	116	(2) x 60 Amp @ 24 VDC	6 AWG	6 AWG	4 AWG	2 AWG	2 AWG
E-Driv	40	50 Amp @ 48 VDC	10 AWG	10 AWG	10 AWG	10 AWG	10 AWG

NOTICE: Wire Extension Length refers to the distance from the batteries to the trolling motor leads. Consult website for available thrust options. Maximum Amp Draw values only occur intermittently during select conditions and should not be used as continuous amp load ratings.

Reference

United States Code of Federal Regulations: 33 CFR 183 – Boats and Associated Equipment ABYC E-11: AC and DC Electrical Systems on Boats

SELECTING THE CORRECT BATTERIES

////////////////////////////////////

SELECTING THE CORRECT BATTERIES

The motor will operate with any lead acid, deep cycle marine 12 volt battery/batteries. For best results, use a deep cycle, marine battery with at least a 60 amp-hour rating. Maintain battery at full charge. Proper care will ensure having battery power when you need it and will significantly improve the battery life. Failure to recharge lead-acid batteries (within 12-24 hours) is the leading cause of premature battery failure. Use a multi-stage charger to avoid overcharging. We offer a wide selection of chargers to fit your charging needs. If you are using a crank battery to start a gasoline outboard, we recommend that you use a separate deep cycle marine battery/batteries for your MAKOSHARK trolling motor. For more information on battery selection and rigging, please check with related departments.

WARNING

Never connect the (+) and the (-) terminals of the same battery together. Take care that no metal object can fall onto the battery and short the terminals. This would immediately lead to a short and extreme fire danger.

CAUTION

Refer to “Conductor Gauge and Circuit Breaker Sizing Table” in the previous section to find the appropriate circuit breaker or fuse for your motor.

CAUTION

Please read the following information before connecting your motor to your batteries in order to avoid damaging your motor and/or voiding your warranty.

ADDITIONAL CONSIDERATIONS

› Using DC or Alternator Chargers

Your MAKOSHARK trolling motor may be designed with an internal bonding wire to reduce sonar interference. Most alternator charging systems do not account for this bonding wire, and connect the negative posts of the trolling motor batteries to the negative posts of the crank/starting battery. These external connections can damage connected electronics and the electrical system of your trolling motor, voiding your warranty. Review your charger’s manual carefully or consult the manufacturer prior to use to ensure your charger is compatible.



› Additional Accessories Connected to Trolling Motor Batteries

Significant damage to your MAKOSHARK motor, your boat electronics, and your boat can occur if incorrect connections are made between your trolling motor batteries and other battery systems. MAKOSHARK recommends using an exclusive battery system for your trolling motor. Where possible, accessories should be connected to a separate battery system. Radios and sonar units should not be connected to any trolling motor battery systems as interference from the trolling motor is unavoidable. If connecting any additional accessories to any trolling motor battery system, or making connections between the trolling motor batteries and other battery systems on the boat, be sure to carefully observe the information below. The negative (-) connection must be connected to the negative terminal of the same battery that the trolling motor negative lead connects to. In the diagrams below this battery is labeled “Low Side” Battery. Connecting to any other trolling motor battery will input positive voltage into the “ground” of that accessory, which can cause excess corrosion. Any damage caused by incorrect connections between battery systems will not be covered under warranty.

The negative (-) connection must be connected to the negative terminal of the same battery that the trolling motor negative lead connects to. In the diagrams below this battery is labeled “Low Side” Battery. Connecting to any other trolling motor battery will input positive voltage into the “ground” of that accessory, which can cause excess corrosion. Any damage caused by incorrect connections between battery systems will not be covered under warranty.

› Automatic Jump Start Systems and Selector Switches

Automatic jump start systems and selector switches tie the negatives of the connected batteries together. Connecting these systems to the “High Side” Battery or “Middle” Battery in the diagrams below and will cause significant damage to your trolling motor and electronics. The only trolling motor battery that is safe to connect to one of these systems is the “Low Side” Battery.

CONNECTING THE BATTERIES

› 12-Volt Systems

1. Make sure that the motor is switched off (speed selector on “OFF” or “0”).
2. Connect positive (+) red lead to positive (+) battery terminal.
3. Connect negative (-) black lead to negative (-) battery terminal.

WARNING

For safety reasons do not switch the motor on until the propeller is in the water. If installing a leadwire plug, observe proper polarity and follow instructions in your boat owner’s manual.

PARTS DIAGRAM & PARTS LIST

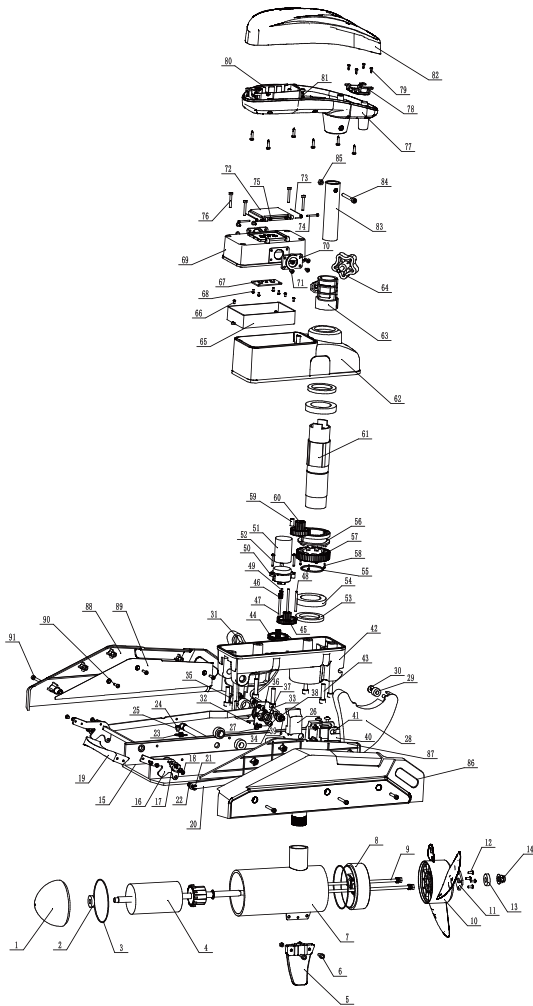

PARTS DIAGRAM & PARTS LIST 1

item	description	quantity	specification
1	Motor front cover	1	
2	Deepgroove ball bearings	1	61900-2RS
3	O-ring seals	1	6*5
4	Rotor assembly	1	
5	Fins	1	
6	m5*16 hexagonal bolts	2	
7	Motor barrel	1	
8	Motor backseat	1	
9	m6*232 bolts	2	
10	Propeller	1	
11	Propeller pressure plate	1	
12	Cross recessed pan head tapping screws	4	4. 2*16
13	Anti-corrosion zinc block	1	
14	m10 lock nuts	1	
15	Base plate	1	
16	Pedal support	2	
17	Square shaft cover	2	
18	Cross recessed pan head screws	18	M4*6
19	Pedal	1	
20	Left and right connecting rods	1	
21	E-Clip	2	d5
22	Slotted Pins	2	
23	Tension Spring	2	
24	Tension spring spacer	2	
25	Cross recessed large round head screws	2	m5*10
26	Gearbox left and right spacers	1	
27	Copper bushing	2	
28	Left and right support plate	1	
29	Pulley	4	
30	Cross recessed pan head screws	4	3. 5*9. 5
31	Lower housing sealing strip	1	
32	Torsion spring	2	
33	Torsion Spring Plate	2	
34	Cross recessed pan head tapping screws	8	3. 5*9. 5
35	M14*1. 5 studs	2	
36	Elastic spring for shaft	4	
37	Support plate spacer	2	
38	Igus spacer	4	D10*D18*1
39	Elastic Circlips for Shaft	2	d10
40	Fixed wall plate	2	
41	Cross recessed large flat head screws	4	6*8
42	Gearbox lower housing	1	
43	Hexagonsocket head cap screws	6	8*35
44	Primary reduction gear	1	
45	Secondary reduction gear	1	

PARTS DIAGRAM & PARTS LIST 2

item	description	quantity	specification
46	Main gear	1	
47	Cylindrical pin	2	4*60
48	Cylindrical pin	1	4*45
49	Cross recessed pan head screws	2	4*6
50	Motor Support Block	1	
51	Motor motor	1	
52	Cross recessed pan head screws	2	4*20
53	Double Lip TC Simmerring Oil Seal	2	45*62*7
54	Deep Groove Ball Bearing	2	61909-zz
55	Shaft Retaining Ring	1	d47
56	Coupling	1	
57	51-tooth output gears	1	
58	Cross recessed pan head tapping screws	4	2.9*8
59	Secondary reduction gear spacer	1	
60	Tertiary reduction gears	1	
61	Aluminum tube output shaft	1	
62	Gearbox upper housing	1	
63	Left and right positioning latches	2	
64	Locking handle	1	m8
65	Control Plate	1	
66	Cross recessed pan head screws	3	3*6
67	Lamp Plate Assembly	1	
68	Cross recessed pan head screws	4	3*6
69	Upper Housing Circuit Board Cover	1	
70	Waterproof Pressure Plate	2	
71	Cross recessed large flat head screws	8	4*10
72	Indicator Lamp Plastic Housing	1	
73	Plastic Cover Closing Spring	2	
74	Hexagon socket cheese head screws	2	3*25
75	Lock nuts	2	
76	Hexagon socket cheese head screws	4	4*30
77	Upper Rudder Lower Housing	1	
78	Spring Wire Plate	1	
79	Screws	4	
80	Signal Receiver	1	
81	Cross recessed pan head screws	4	2.9*9.5
82	Upper rudder upper housing	1	
83	Intermediate support tube	1	
84	Hexagon socket head cap screws	1	6*50
85	Lock Nut	1	m6
86	Right cowling	1	
87	Right cowling cover	1	
88	Left housing	1	
89	Left Cover Cover Plate	1	
90	Cross recessed pan head tapping screws	6	4.2*16
91	Cross recessed large flat head screws	6	5*14



MAKO SHARK

OMAS SERIES

MAKO TECHNOLOGIES (TAIZHOU)CO.,LTD.

Manufacturer Address: #17 Shanhai Rd,Eastern Area,Wenling,Zhejiang ,China.

Province 317511, China.

Design Office: 2809 Fairfield Ave.Greensboro,NC 27408,USA.

Email: mk@makoshark.cn

Website: www.makoshark.cn



Scan the code to contact us